

30x30x10mm

Model B

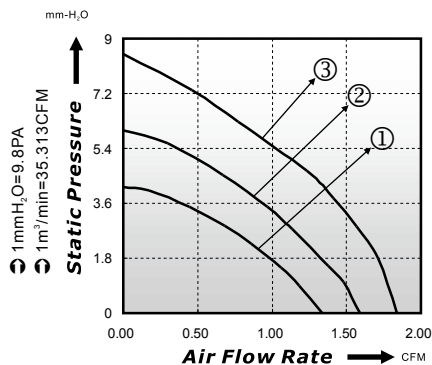

P-Q Curve (At Rated Voltage)



Dimensions Drawing

Unit: (mm)

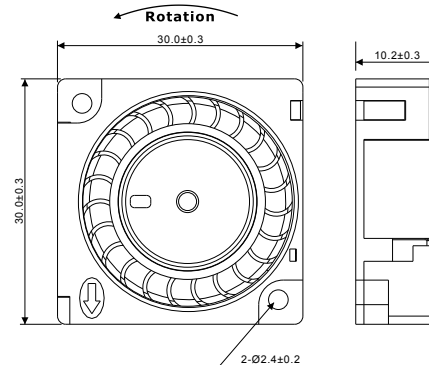

Model No	Bearing (*)	Rated Voltage (VDC)	Rated Current (A)	Power Consumption (Watts)	Speed (rpm)	Air Flow (CFM)	Static Pressure (mmH ₂ O)	Noise (dBA)	Curve
EBD03010-05L*	○ ● ⊖	5	0.12	0.60	5500	1.34	4.14	21.7	1
EBD03010-05M*	○ ● ⊖	5	0.22	1.10	6500	1.59	6.00	25.1	2
EBD03010-05H*	○ ● ⊖	5	0.27	1.35	7500	1.84	8.50	29.5	3
EBD03010-12L*	○ ● ⊖	12	0.08	0.96	5500	1.34	4.14	21.7	1
EBD03010-12M*	○ ● ⊖	12	0.12	1.44	6500	1.59	6.00	25.1	2
EBD03010-12H*	○ ● ⊖	12	0.15	1.80	7500	1.84	8.50	29.5	3

* Bearing Type: ○ Sleeve ● Two Ball ⊖ Hydro-Dynamic